

ASCE Geotechnical Division Specialty Conference
Grouting, Soil Improvement and Geosynthetics
New Orleans, Louisiana

February 25-28, 1992

IN-SITU STABILIZATION AND FIXATION OF
CONTAMINATED SOILS BY SOIL MIXING

Brian H. Jasperse, P.E.¹, M.ASCE and
Christopher R. Ryan, P.E.², M.ASCE

Abstract

Soil mixing for the improvement of the properties of soil has been in use in various forms in the United States for nearly thirty years. With the costs of environmental remedial work soaring, engineers have been looking for more economical methods to solve pollution problems. Soil mixing offers a proven, inexpensive method for stabilizing or fixating contaminated soils and sludges.

Soil mixing can be divided into two categories - Deep Soil Mixing (DSM) and Shallow Soil Mixing (SSM). DSM entails the use of up to four mixing shafts approximately 1 meter in diameter, able to mix as deep as fifty meters. SSM consists of one large mixing shaft, two to four meters in diameter, capable of mixing ten meters deep.

The mixing shafts on the DSM system are hollow stemmed and have intermittent flighting which breaks the soil loose and lifts it slightly to beater bars on the mixing shaft. As the mixing shafts penetrate the soil, the reagent or slurry is pumped out the tips of the stems and the soil that is broken loose is mixed in a pugmill fashion by the beater bars. The one meter diameter shafts are overlapped so as to create a continuous treatment.

The mixing shaft for SSM is also hollow stemmed. It has one auger flight and six beater bars. The

¹Vice President, Construction, Geo-Con, Inc., P. O. Box 17380, Pittsburgh, PA 15235

²President, Geo-Con, Inc., P. O. Box 17380, Pittsburgh, PA 15235

mixing works in the same manner as in DSM.

The systems are capable of injecting and mixing a slurry or, in some cases, dry materials. Instrumentation controls the reagent flow rate to assure that laboratory-developed mix designs are duplicated in the field. Real-time readouts are printed containing information on flow, pressure, elevation and other parameters.

Two case studies will be discussed. These projects will be detailed from treatability studies to final field remediation. The first case involves the fixation of PCBs in a sandy soil under the groundwater table. A test project was initially performed under the U.S.E.P.A. Superfund Innovative Technology Evaluation program and involved the use of a proprietary fixation agent and DSM. The full scale application to the site has recently been completed.

The second case is the remediation of a large oily sludge lagoon using the SSM technology and a dry reagent. This project required solidification of the waste to the point where it could be used as a future foundation for heavy tanks.

There are other actual and potential uses of DSM and SSM including steam stripping and bioremediation. The equipment can be modified to contain and treat VOCs and other fugitive emissions.

The cost of using DSM and SSM for remedial purposes is usually one half to one tenth of other solutions. As it gains acceptance, it will become the method of choice on numerous projects.

Introduction

The roots of soil mixing technology go back to the 1960's. An early U.S. patent (Liver) describes a process which came to be known as Mixed In Place Piles, in which a mechanical mixer was used to mix a cement grout into the soil for the purpose of creating foundation elements and retaining walls (Fig. 1). In the 1970's, similar equipment was extensively used in Scandinavia for the introduction of lime slurries into soft clays for stabilization (Broms and Boman, 1979). More recently we have seen the advent of a technology called deep soil mixing (DSM). This originated in Japan where several companies applied gangs of auger mixers to inject and mix cementitious grouts into soils. These were used for underwater foundations (ENR, 1983) for earthquake protection (ENR 1989) and

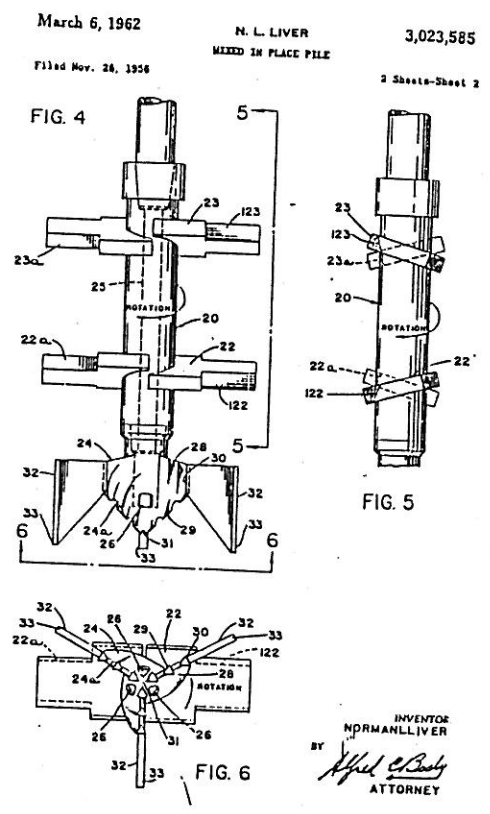
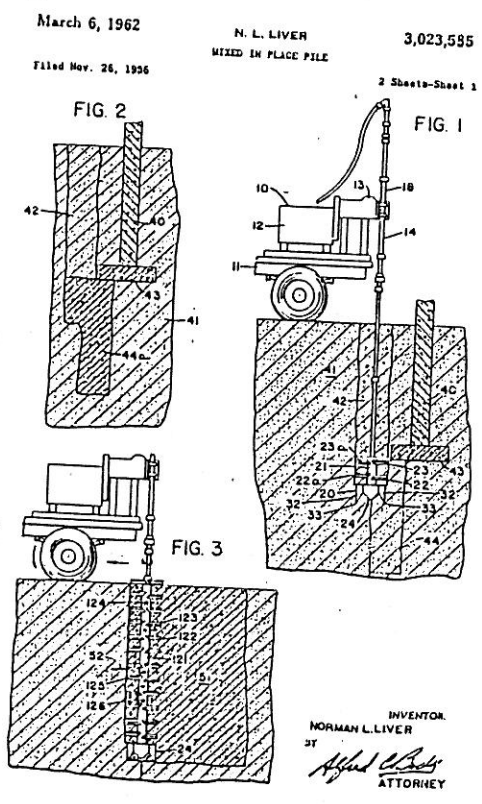

Figure 1. Diagrams From Early Patent

for retaining walls (ENR, 1986). In the mid 1980's, the system was introduced on a U.S. project (Jasperse and Ryan, 1987); an early use was for protection of a structure from soil liquefaction during earthquakes (ENR, 1987).

It was apparent early on in the U.S. experience that some of the advantages of the soil mixing methodology would apply very well to the remediation of contaminated soils and groundwater at hazardous waste sites. First and foremost, it is an in-situ treatment method that is favorably received under current legislation affecting the selection of remedial technologies, mainly because the soil and groundwater are treated in place without removal. A second advantage is the substantial reduction of volatilization that would be experienced when some contaminated materials are brought to the surface and exposed to the atmosphere. Other technical advantages apply as well; for example, the elimination of excavated pits that might endanger surrounding structures, low vibration levels and excellent mixing efficiencies.

The low cost of these systems has provided a major incentive for their use. With the DSM technology, it has been possible to treat soils to depths in the range of 5-30m for a typical cost of \$100-200 per cubic meter. To this figure must be added the cost of the treatment reagent, but the total cost is a fraction of that of alternatives such as landfill disposal or incineration.

A recent advance has been the application of much larger diameter mixing heads for shallower soil deposits and for sludge lagoons. Dubbed "Shallow Soil Mixing" or SSM, this system is more productive and reduces typical treatment costs for soils and sludges from 2-8m deep to \$20-50 per cubic meter. Again, the cost of treatment reagents would be additional. This system permits the use of dry reagents and an effective vapor collection apparatus. It can be used with cementitious, chemical or even biological reagents as required to treat a particular waste (Jasperse, 1989). A variant on the soil mixing technology uses steam or hot air to extract volatile pollutants from the subsoil (Roy 1990, Diaz and Guenther 1990).

The balance of the paper focuses on two case studies where in-situ fixation or stabilization was accomplished by soil mixing. The first is in-situ fixation of PCB's using the DSM method on a site in Hialeah, Florida. The second is the solidification of an oily sludge lagoon near Chicago, Illinois.

Deep Soil Mixing Case Study

The work was carried out at the site of an abandoned transformer repair facility near Miami, Florida. Leaks of transformer oil had contaminated the soil below the old shop to depths up to 15m. After an extensive study of applicable reagents and potential mixing methods, the owner selected a proprietary cement-based additive and the deep soil mixing technology as the most effective and economical remediation. The proximity of other businesses made excavation of the contaminated soil impractical and the cost of disposal by incineration was prohibitive.

The soil profile consisted of sands, silty sands and karstic lime rock. The water table was approximately 2m below the ground surface. PCB concentrations varied from nondetectable to about 1,000 ppm. Over much of the affected area, they were in the range of 200-600 ppm.

The work was executed in three phases. First, an extensive laboratory bench scale program was carried out to select the reagent and the proportions needed for treatment. Second, a pilot scale demonstration was run at the site using a small-scale rig. Last, full scale treatment of the site was carried out.

The reagent selected after the bench scale study was a proprietary pozzolanic additive containing treated clay absorbents designed to chemically bind PCB's and other organics. The pilot scale program was run in 1988 and consisted of treatment of two small areas with extensive pre and post treatment testing. Because of the lack of mobility of PCB's, pretreatment TCLP tests were generally not able to detect PCB's in the leachate if untreated soil samples contained less than 60 ppm PCB. If the untreated soil samples contained more than 300 ppm, then the TCLP test detected PCBs in the leachate. Between 60 and 300 ppm the results varied.

Treated samples all contained PCB levels of 170 ppm or less, with most below 100 ppm. TCLP tests on the treated samples yielded nondetectable results on every sample. Detailed results of the pilot scale program are available through EPA's SITE (Superfund Innovative Technology Evaluation) Program (EPA 1990, EPA 1991).

The final phase of the work, complete treatment of the site, began in late 1990 and was completed in the spring of 1991. The equipment consisted of a four shaft DSM rig (Fig. 2) and a reagent mix plant complete with a four line pump and control system (Fig. 3).

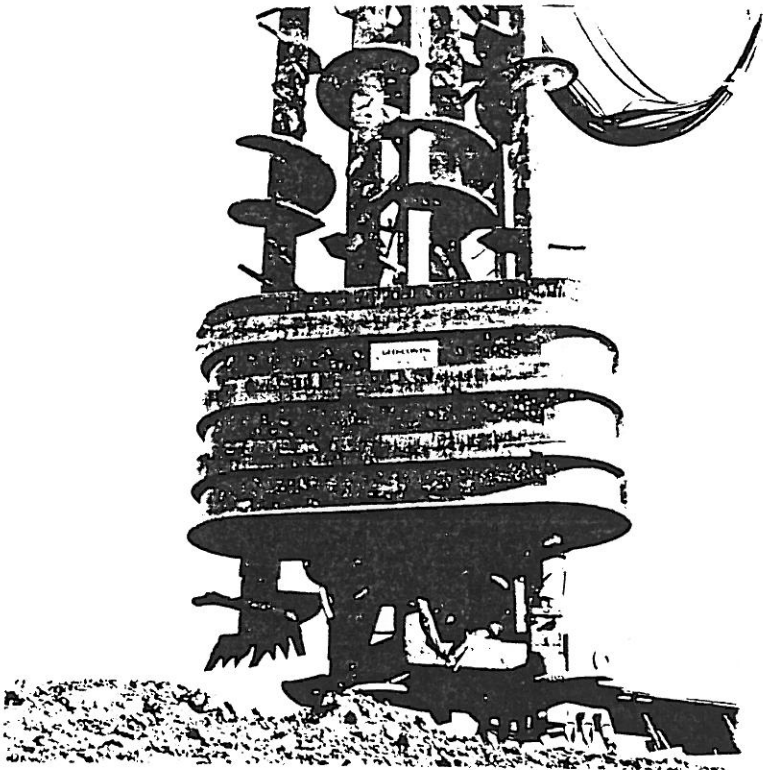
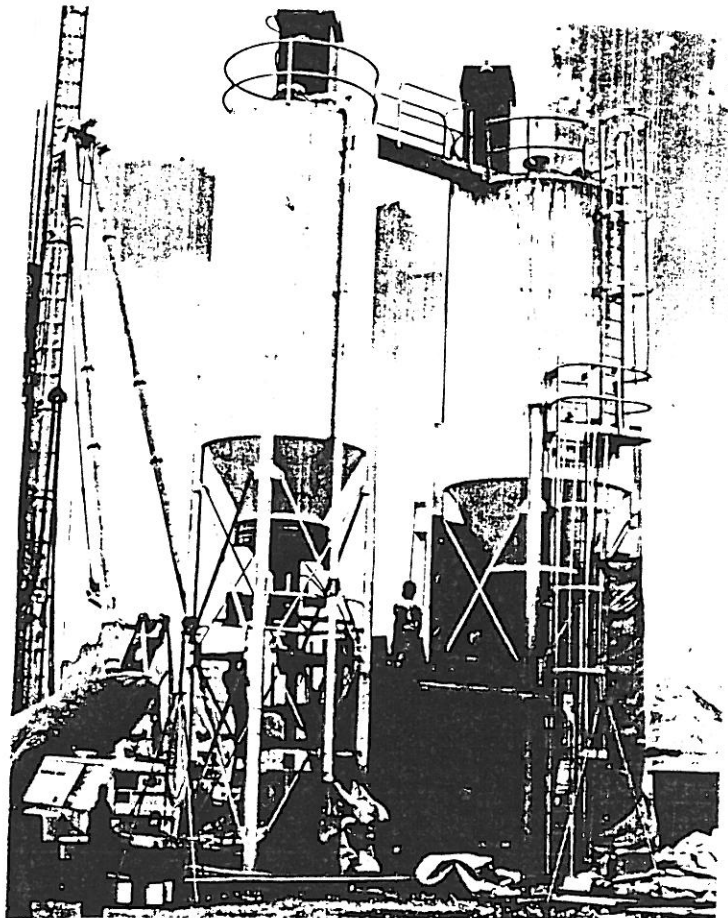

Figure 2.
Four Shaft DSM Rig

Figure 3.
DSM Mix Plant



This equipment is capable of treatment to depths of 30 meters in a single pass, although, in this case, treatment depth ranged from four to fifteen meters. A sophisticated control system monitors the flow of the reagent grout to the mixing augers and ensures accurate mix proportions. The rig worked across the site in a series of four-shaft primary and secondary strokes (Fig. 4). Primary strokes were allowed to set prior to drilling the secondaries. Sufficient overlap is allowed to ensure continuity and complete treatment of all the site soils.

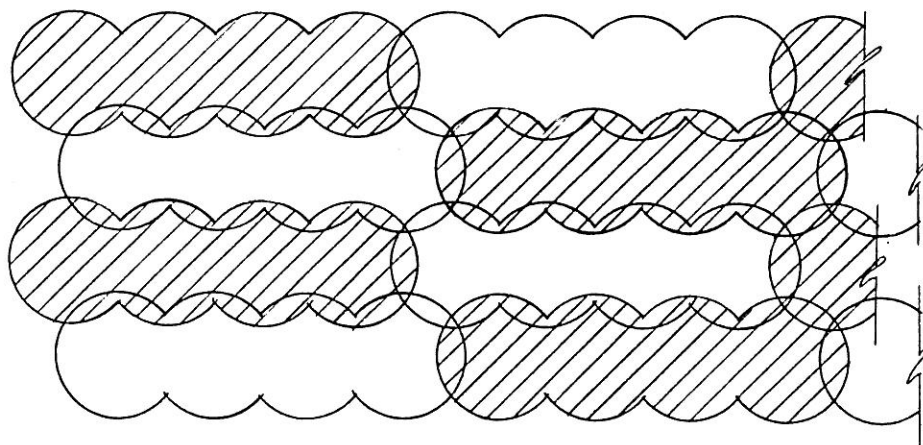

Figure 4. Four Shaft DSM Pattern

Because PCB's are relatively immobile, TCLP tests did not show detectable leaking of PCB's either before or after the tests. In the pilot test, average PCB concentrations were lower in mixed samples than the average of pretreatment samples (Fig. 5), although the mixing process prevents good correlation of data.

With respect to strength and permeability, extensive data is available. The addition rate was 17% by dry weight to soil or approximately 275 kilogram per cubic meter of soil mixed. The data presented in Figures 6 and 7 from the pilot test show that excellent results for both strength and permeability were obtained and that the results improved after one year.

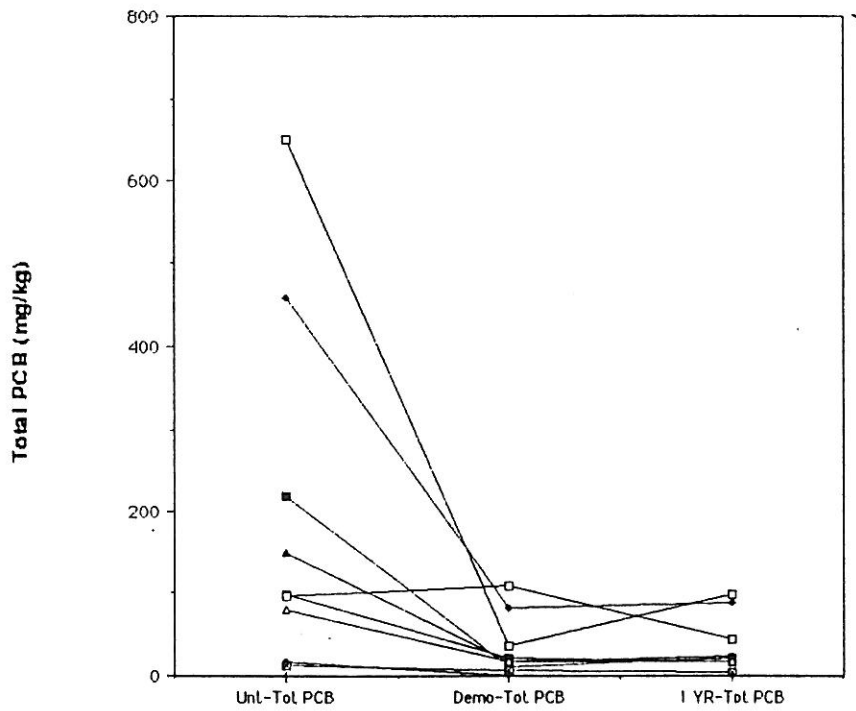

Figure 5. PCB Concentration Before and After Treatment

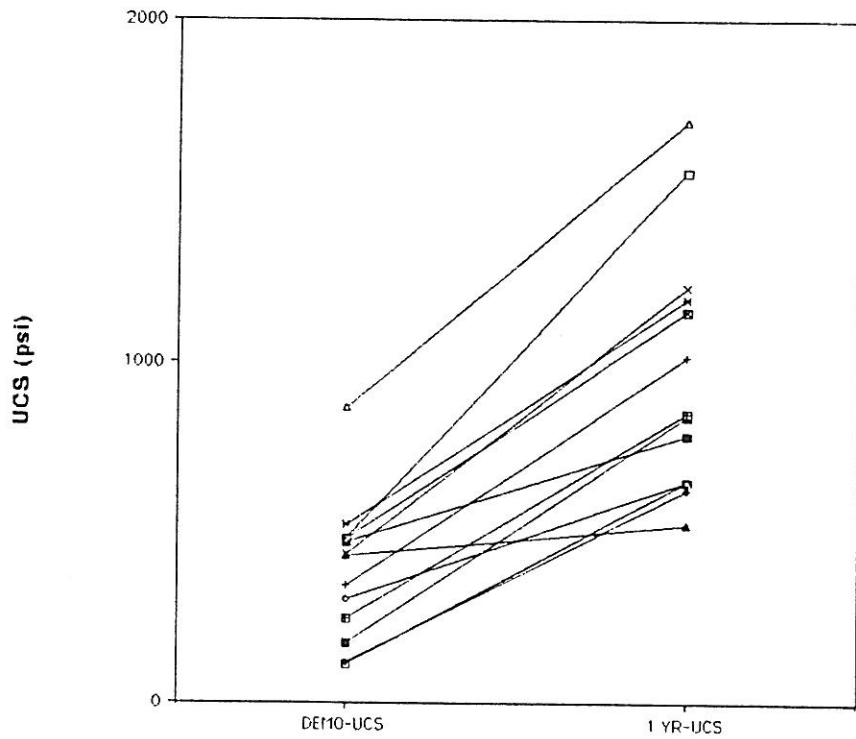

Figure 6. Unconfined Strength of Mixed Samples Vs. Time

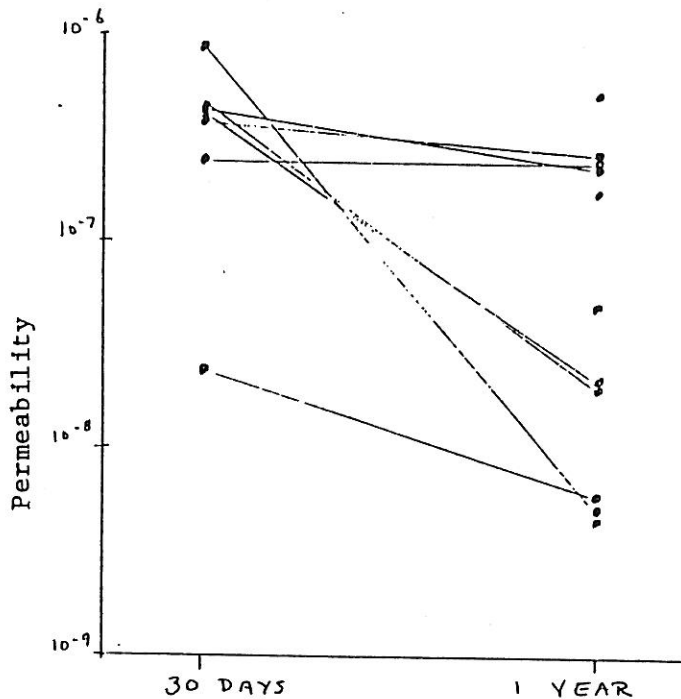

Figure 7. Permeability of Mixed Samples Vs. Time
Shallow Soil Mixing Case Study

The project is a large lagoon containing sludge residues from a water treatment plant at a refinery near Chicago. The lagoons were to be solidified and enclosed in a cap and vertical barrier containment system. The owner planned to reuse the site as a tank farm, so the solidified material had to meet rigid standards for strength, i.e. 35 p.s.i. unconfined compressive strength in 28 days. Also each sample had to pass a free liquids test (Paint Filter - EPA SW 846). The sludge was an oily paste containing oil, grease and petroleum hydrocarbons as primary constituents. The depth of treatment varied from about three to five meters, including one meter of underlying soils.

It was of great concern that there be no dust and that emission of volatiles be kept to a minimum. Pre-job bench scale testing indicated that cement, added in the 15-20% range, would be the optimal reagent. Because the sludge had a relatively high water content (typically 55 - 65%), it was not desirable to add the reagent in the form of a slurry or grout, since this would greatly increase the amount of cement required and lead to substantial volume expansion.

The technology selected was Shallow soil Mixing or SSM. This equipment consists of a large diameter mixer head enclosed by a hood or shroud (Fig. 8). Reagent is applied through a dry pneumatic transfer system that is totally enclosed and which has bag houses at all termination points. The final application to the sludge is made with the hood lowered, so that dust is practically eliminated. The system has the further advantage that any emissions of gases caused by the mixing process can be collected under the hood and exhausted for treatment. Generally, as in this case, the in-situ mixing produces little offgassing and no collection of fugitive emissions is necessary.

The work began in late 1990 and is expected to conclude in late 1991. Work progresses, as in the case of DSM, by drilling a series of primary and secondary shafts, allowing the primaries to set before drilling secondaries. In this case, the rig supporting the SSM equipment was able to walk over and work on the stabilized material after about two weeks.

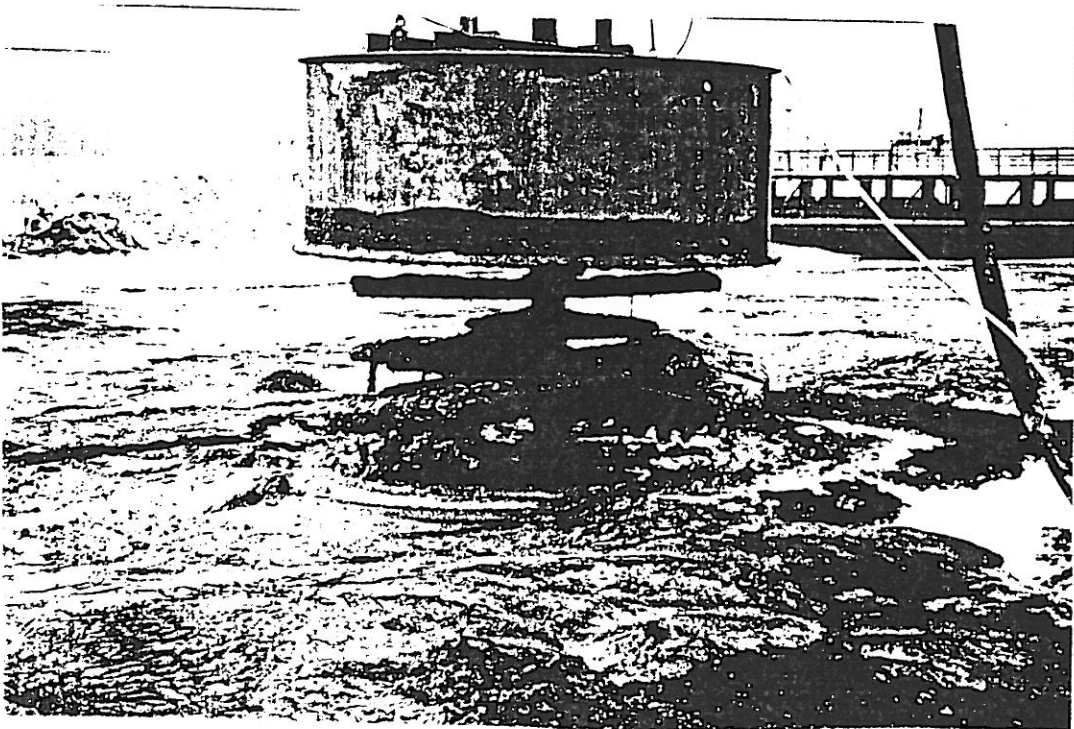

Figure 8. SSM System

Data for mix strengths measured in the field are presented in Fig. 9. It can be seen that the greater the amount of cement, the higher the U.C.S. Also, there is strength gain from 14 to 28 days.

As can be seen in the data, strengths can be obtained that would allow the solidified sludge to be utilized as a foundation supporting significant loads. Also, all samples passed the free liquids test.

The 12% results seem to indicate that a minimum amount of cement is needed to produce any significant results. In this case, 15% seemed to be the minimum.

As in the case of the previously cited DSM project, the results are expected to substantially improve with time.

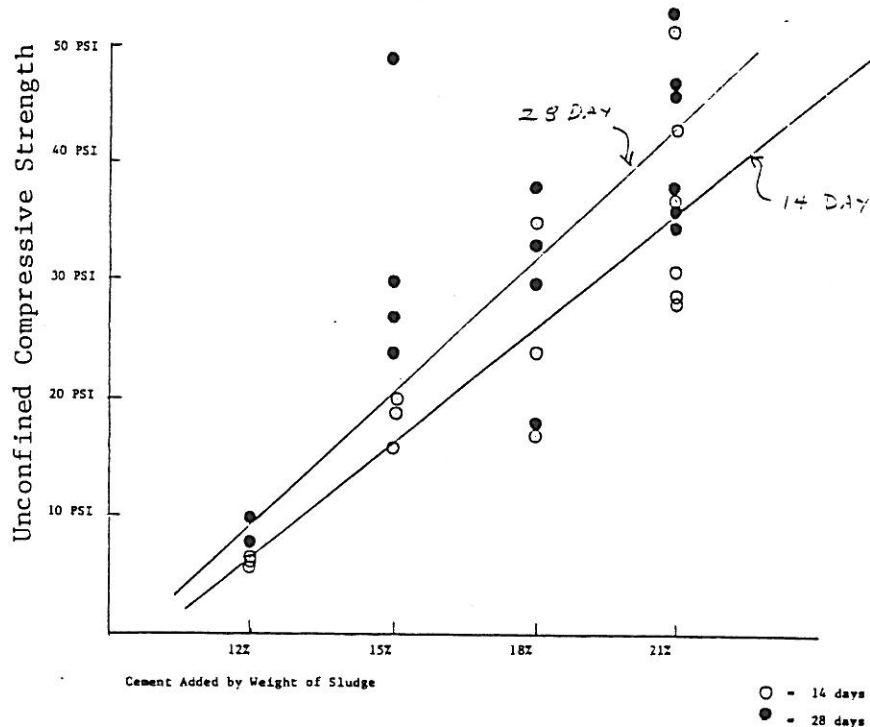

Figure 9. Unconfined Strength Vs. Time

Conclusion

The new in-situ mixing technologies are particularly applicable to major sites that contain contaminated soils and sludges. In-situ mixing has now been used on over a dozen project in the U.S. in the last few years. The economic and practical advantages of in-place treatment are substantial and the current regulatory environment favors this type of solution over offsite transport and disposal. We see a large amount of potential application for this work.